

## Terminal Markings

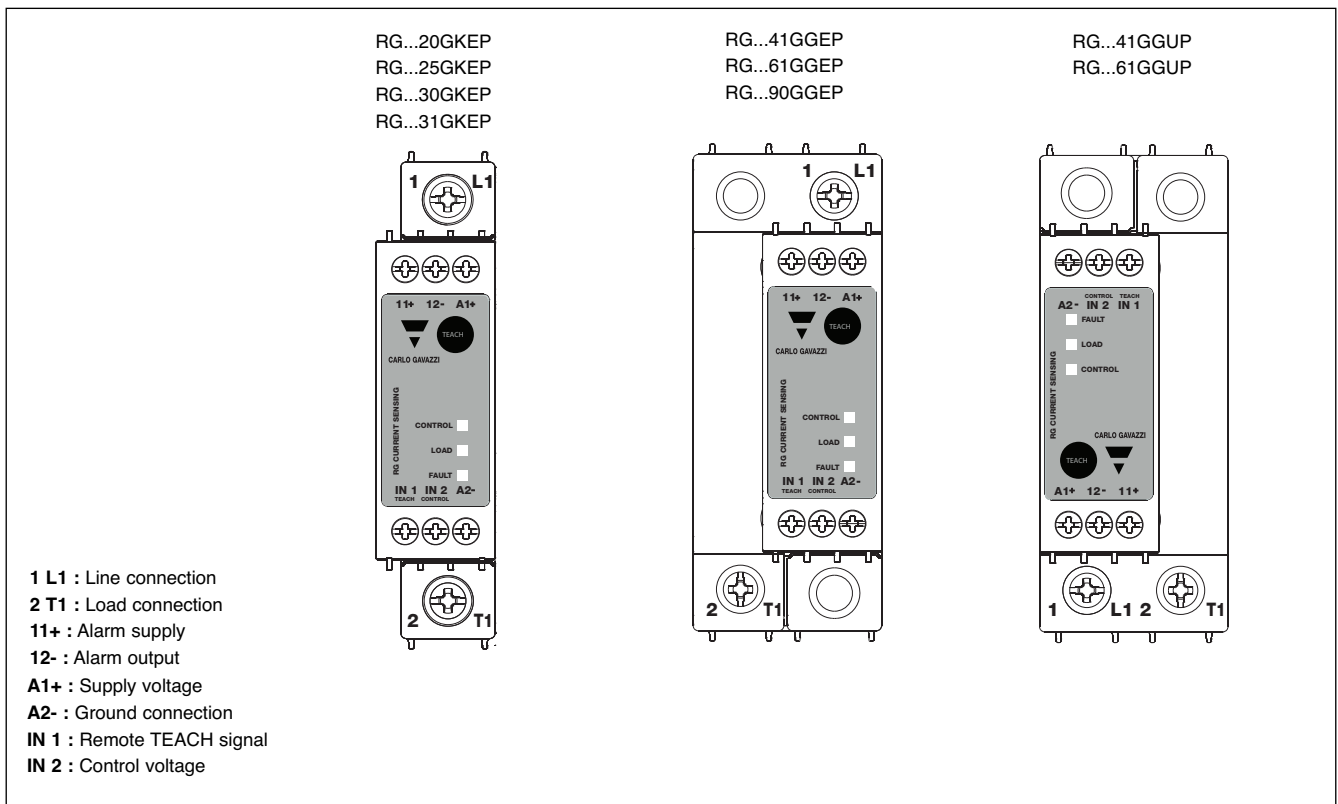

Note:  
 - Local TEACH by pressing front button for more than 3 sec but less than 5 sec  
 - Fan supply (24VDC) for RGC1A60D90GGEP has to be supplied directly to fan

## Connection Diagram

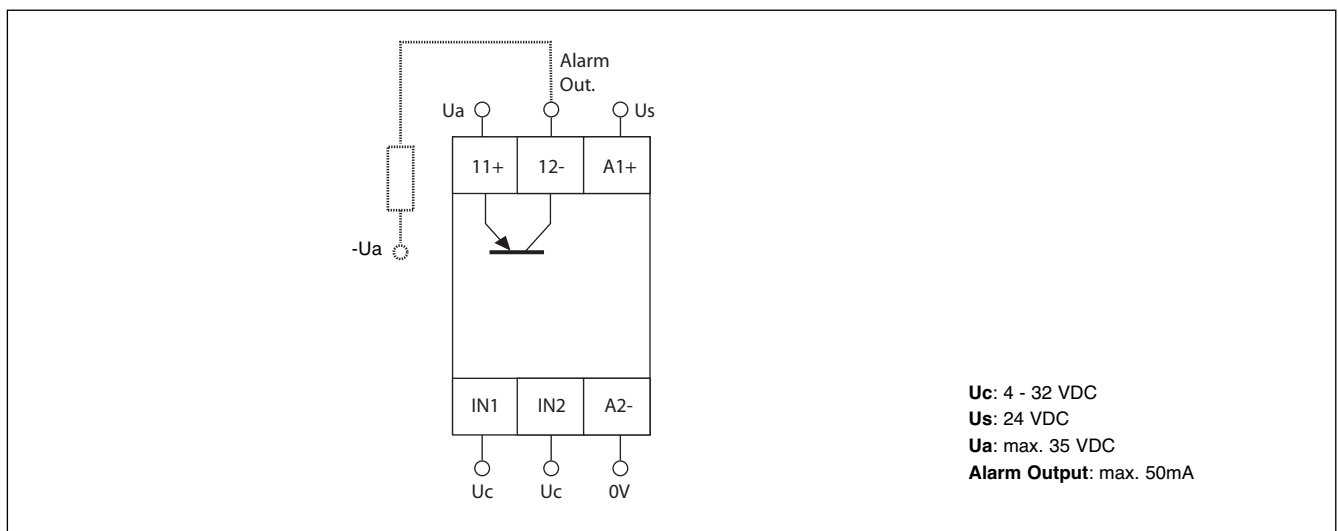

## Connection Diagram for Separate Alarm Outputs

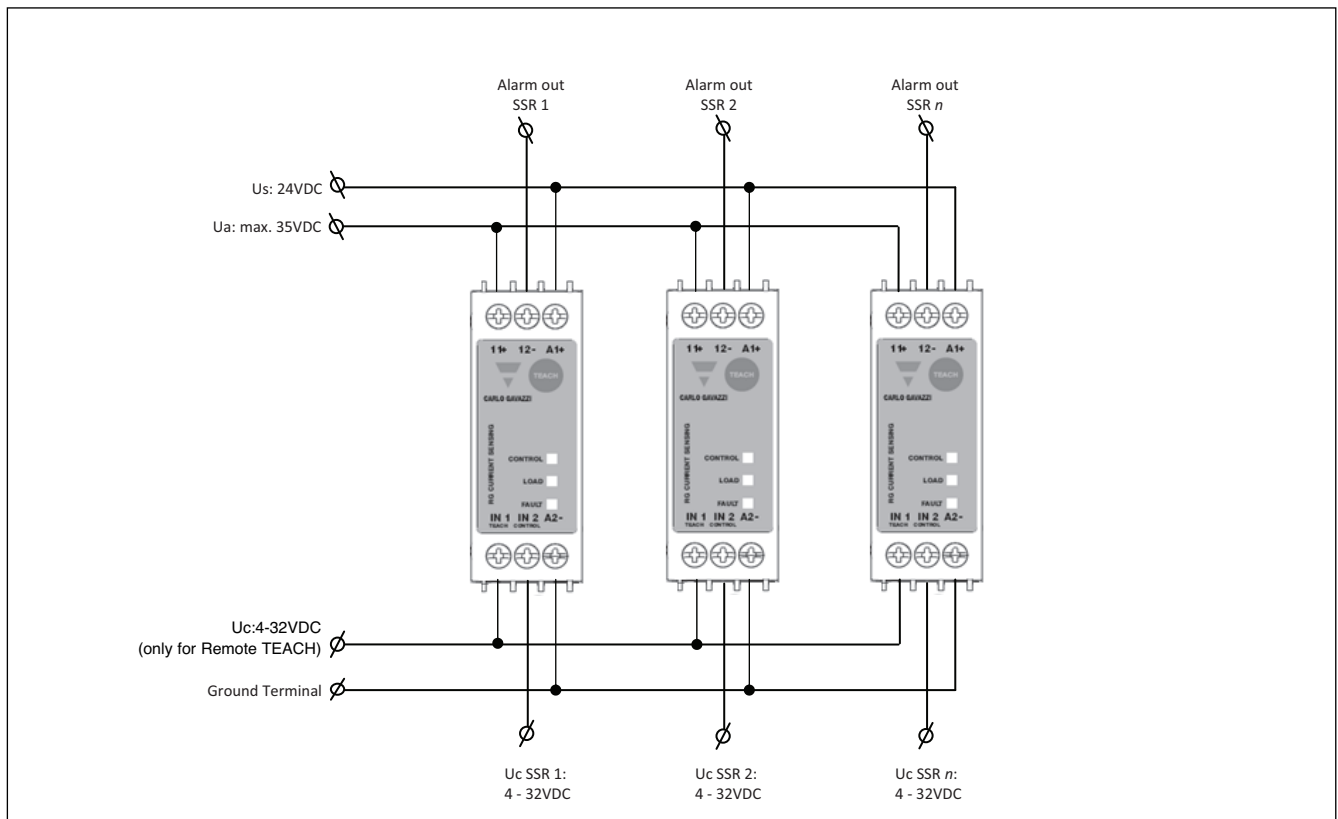

## Connection Diagram for Series Alarm Outputs

